

Quality, Reliability & Versatility NOW BETTER!



- New Compact size fits 24" spaces, with a full size heat recovery core
- All 4 ports have self-locking dampers for adjustable airflow
- 3 selectable high speed settings accommodates multiple ventilation rates
- Installer-friendly features:
 - Door Port Balancing
 - Light Weight
 - No side access required
 - Motor slides out for service



Setting a new standard
for energy efficient, clean air homes



Visit us at www.lifebreath.com

Engineering Data

THERMALLY CONDUCTIVE, PATENTED ALUMINUM CORE

The cross-flow heat recovery core transfers heat between the two airstreams. It is easily removed for cleaning or service.

MOTORS AND BLOWERS

Each air stream has an independent motorized impeller. Multiple high speed fan operation.

FILTERS

Washable air filters in exhaust and supply air streams.

DEFROST

Recirculating damper defrost system.

CASE

Twenty gauge prepainted galvanized steel for superior corrosion resistance. Insulated to prevent exterior condensation. Drain connection 1/2" (12 mm) OD. Balancing ports are located in the door.

MOUNTING THE HRV

Four threaded inserts at corners of the cabinet designed to accept the "S" hooks and adjustable hanging straps supplied with the unit.

RNC SERIES ELECTRONICS

- Built-in Relay for Interfacing to furnace.
- A standard ON/OFF switch can be added to provide Low/High Ventilation or ON/OFF functionality in order to meet building standards.
- Optional controls can be installed at the time of the installation or at a later date to upgrade the basic features of the ventilation system.

OPTIONAL CONTROLS

99-DX-01 Lifestyle RNC Digital Control

- 2 Speed Operation on each mode • 4 user selectable operational modes: Continuous Ventilation, 20 ON/40 OFF, 20 ON/40 Recirculation, Continuous Recirculation.
- Adjustable Dehumidistat function built into the main wall control.
- Connect to 3 wire 20 gauge low voltage wire.

99-BC-01 Lifestyle RNC Ventilation Control

- 2 Speed Fan setting (Low/High) • Dehumidistat
- Connect to 3 wire 20 gauge low voltage wire.

OPTIONAL TIMERS

99-DET01 Lifestyle 20/40/60 Minute Timer - Initiates high speed ventilation for 20, 40, or 60 minutes, (3 wire) 20 gauge wire (min.) 100' length.

99-20M01 Lifestyle 20 Minute Timer - Initiates high speed ventilation for 20 minutes, (3 wire) 20 gauge wire (min.) 100' length.

99-101 Mechanical Timer - Initiates High speed ventilation for up to 60 minutes, (2 wire) 20 gauge wire (min.) 100' length.

OPTIONAL ACCESSORIES

99-DH-01 Lifestyle Dehumidistat - Initiates high speed ventilation when the indoor humidity level is above the set point. (3 wire) 20 gauge wire (min.) 100' length

99-163 Duct Heater w/ Electronic SCR Thermostat, 1 Kw, 6" (150 mm)

99-185 Weatherhoods, Two - 5" (125 mm) c/w 1/4" (6 mm) mesh screen

WEIGHT: 43 lbs (19 1/2kg)

DIMENSIONS: inches (mm)

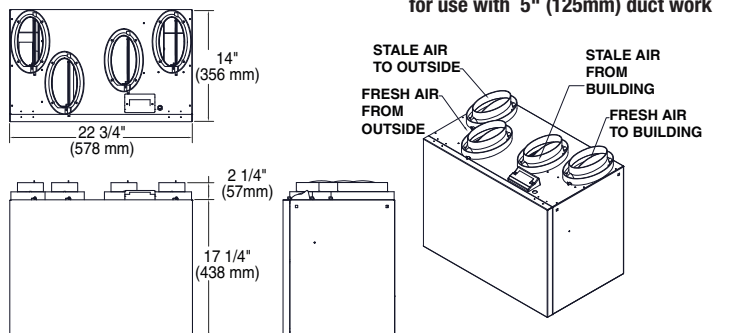

All duct connections are elliptical collars for use with 5" (125mm) duct work

Performance (HVI certified)

Net supply air flow in cfm (L/s) against external static pressure

E.S.P (external static pressure)	[cfm (L/s)]
@ 0.1" (25 Pa)	156 (74)
@ 0.2" (50 Pa)	146 (69)
@ 0.3" (75 Pa)	134 (63)
@ 0.4" (100 Pa)	124 (59)
@ 0.5" (125 Pa)	115 (54)
@ 0.6" (150 Pa)	104 (49)
@ 0.7" (175 Pa)	95 (45)
@ 0.8" (200 Pa)	85 (40)
@ 0.9" (225 Pa)	69 (33)
@ 1.0" (250 Pa)	62 (29)

Max. Temperature Recovery 78%

Sensible Effectiveness

@ 66 cfm (31 L/s) 32°F (0°C) 74%

*Sensible Efficiency @ 66 cfm (31 L/s) 32°F (0°C) 61%

*Sensible Efficiency @ 76 cfm (36 L/s) -13°F (-25°C) 63%

VAC @ 60HZ 120

WATTS / Low speed. 69

WATTS / High speed 147

Amp rating 1.7

*Sensible Efficiency – thermal **Latent Efficiency – moisture

Note: Effectiveness – based on temp. differential between the 2 airstreams
Efficiency – takes into account all power inputs

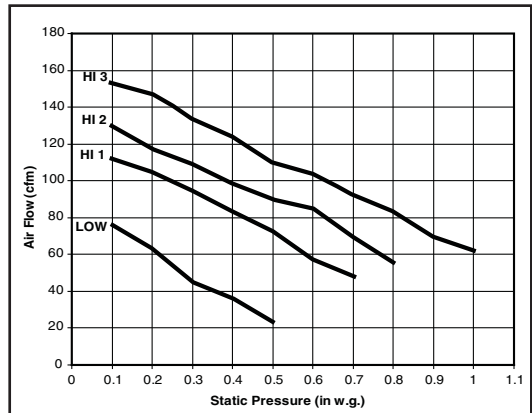

WARRANTY

Units carry a **LIFETIME** warranty on the heat recovery core and a **5 year** replacement parts warranty.

All units conform to CSA and UL Standards.



This product earned the ENERGY STAR by meeting strict energy efficiency guidelines set by Natural Resources Canada and the US EPA. This meets ENERGY STAR requirements only when used in Canada.

511 McCormick Blvd.
London, Ontario, Canada N5W 4C8
Ph: (519) 457-1904

Toll Free: 1-855-AIRIA-00
(1-855-247-4200)

www.lifebreath.com

