

Heat-Duct Air Duct Kit

INSTALLATION AND OPERATION INSTRUCTIONS

APPROVALS

The Heat-Duct air duct kit is for use only on approved Hearth Technologies gas fireplaces.

The flexible duct is manufactured and marked to the requirements of UL-181, Class I air duct.

INTRODUCTION

The Heat-Duct accessory kit conveys warm air from the fireplace through air duct(s) to the entire house via the furnace ductwork (see figure 1). One or two Heat-Duct kits can be installed on the fireplace.

PRELIMINARY PREPARATION

Contents of kit:

- 20-ft. length of 6" round duct
- Fan duct assembly
- Junction box
- Wall switch
- Flex duct collar
- Fan duct collar
- Hardware



Underwriters
Laboratories Listed

*If any parts are missing or damaged, contact your Dealer before starting installation. **DO NOT** install a damaged kit.*

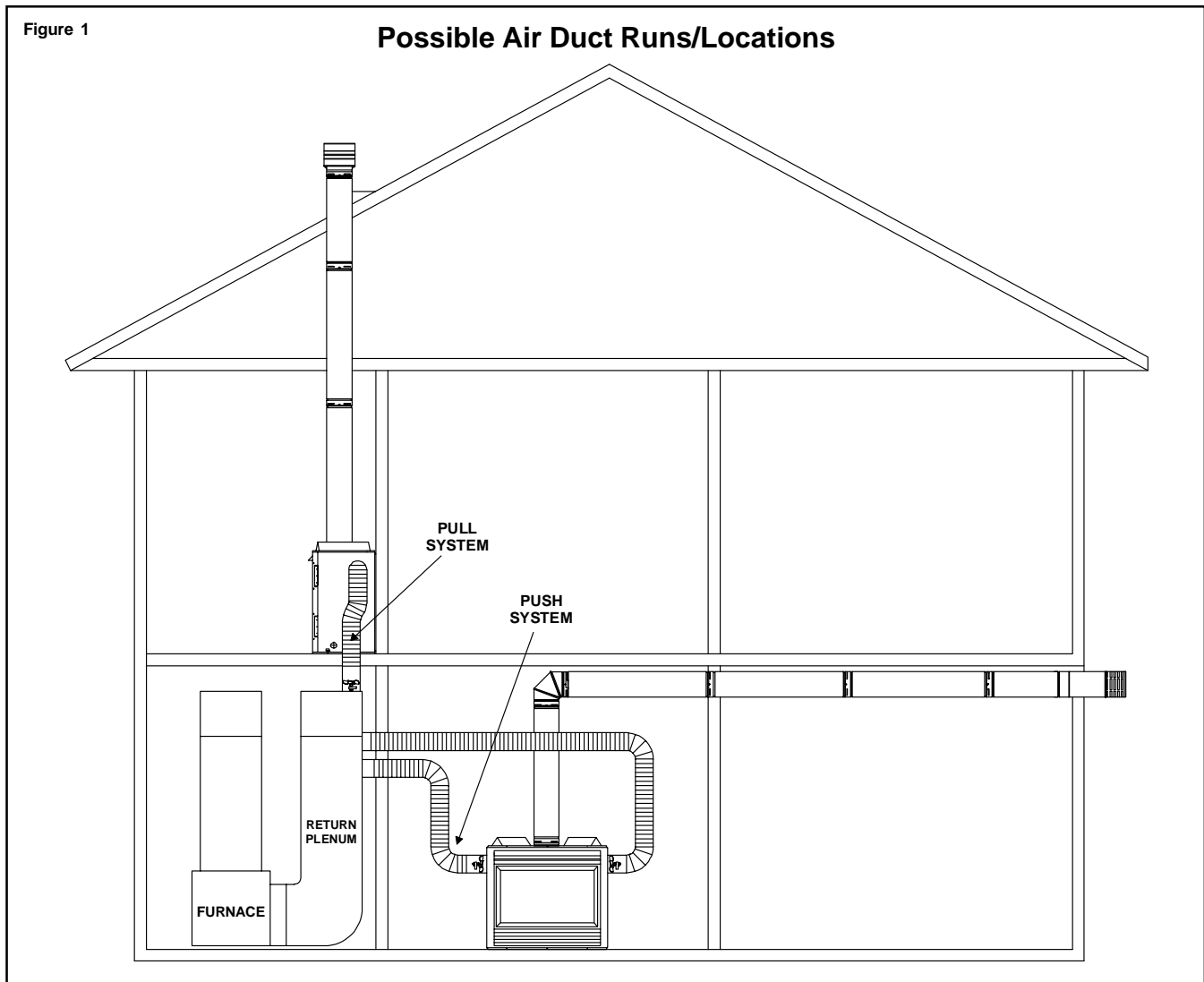

This kit is tested and safe when installed in accordance with this installation manual. It is your responsibility to read all instructions before starting installation and to follow these instructions carefully during installation.

Installation of this kit **MUST** be performed by a qualified service technician.

The Heat-Duct kit is carefully engineered and must be installed only as specified. If it or any of its components are modified, the warranty will be void. Modification may also cause a fire hazard. Installation must be done according to applicable local, state, provincial, and/or national codes.

CAUTION: All wiring should be done by a qualified electrician and in compliance with local codes and with the National Electric Code ANSI/NFPA No. 70-current (In the United States), or with the current CSC22.1 Canadian Electric Code (in Canada).

Plan the location of the fireplace and the warm air duct run(s).

MAXIMUM Duct Run = 20-ft. (6.1m) for useful heat output.

MINIMUM Duct Run = NA - for runs out from the fireplace to adjacent duct.

INSTALLATION

Decide if the fan is going to be mounted to the unit (push system) or if the fan is going to be mounted to the duct return plenum (pull system). Airflow direction is indicated on the fan duct housing. The fan and connections must be accessible for servicing per local code requirements.

If the fan is going to be mounted to the fireplace (**push system**):

- Remove the knockout from the side of the fireplace and discard it.
- Center the fan duct collar (the collar without crimping on the end) around the exposed hole and attach it to the fireplace with 3 screws. **NOTE:** Do this **BEFORE** final positioning of the fireplace (see Figure 2).
- Slide the fan duct assembly onto the collar and secure with three screws. The arrow on the duct should point away from the fireplace. Spin the fan blades and check for obstructions.
- Cut a round 6" hole into the main return plenum of the furnace ductwork. Mount the flex duct collar onto the main return plenum of the furnace ductwork and secure with three screws.
- Connect the fan duct with the flex duct provided. **NOTE:** Fold outer poly layer of flexible duct back to maintain clearance to combustibles on the fireplace. Secure liner to the collar with clamp.
- Support duct at intervals of no greater than four feet, no more than 1/2" sag between supports or as required per local code. **NOTE:** Secure the duct so that clearance to the outer wrap of the fireplace is maintained.
- Tape all seams with aluminum tape (1-1/4" minimum width or as specified by local codes).

If the fan is going to be mounted to the main return plenum of the furnace system (**pull system**):

- Remove the knockout from the side of the fireplace and discard it.
- Center the flex duct collar (the collar with a crimped end) around the exposed hole and attach it to the fireplace with 3 screws. **NOTE:** Do this **BEFORE** final positioning of the fireplace (see Figure 2).
- Cut a round 6" hole into the main return plenum of the furnace ductwork. Mount the fan duct collar onto the main return plenum of the furnace ductwork and secure with three screws.
- Slide the fan duct assembly onto the collar and secure with three screws. The arrow on the duct should point towards the return plenum. Spin the fan blades and check for obstructions.
- Connect the fan duct with the flex duct provided. **NOTE:** The flex duct has a zero clearance to combustible construction.
- Support duct at intervals of no less than four feet with no more than 1/2" sag between supports or as required by local codes.
- Tape all seams with aluminum tape (1-1/4" minimum width or as specified by local codes).

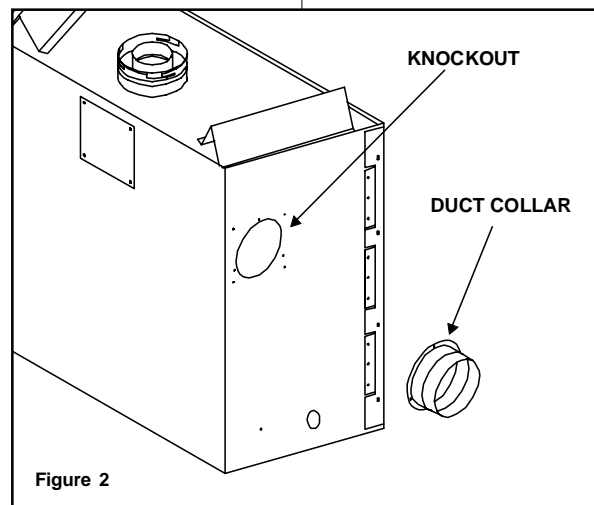

NOTE: The fan duct assembly may be mounted anywhere in the flex duct run that may be convenient. The fan duct collar may need to be crimped to accept the flex ducting. Take care to secure the fan against nuisance vibration. Tape all seams with aluminum tape.

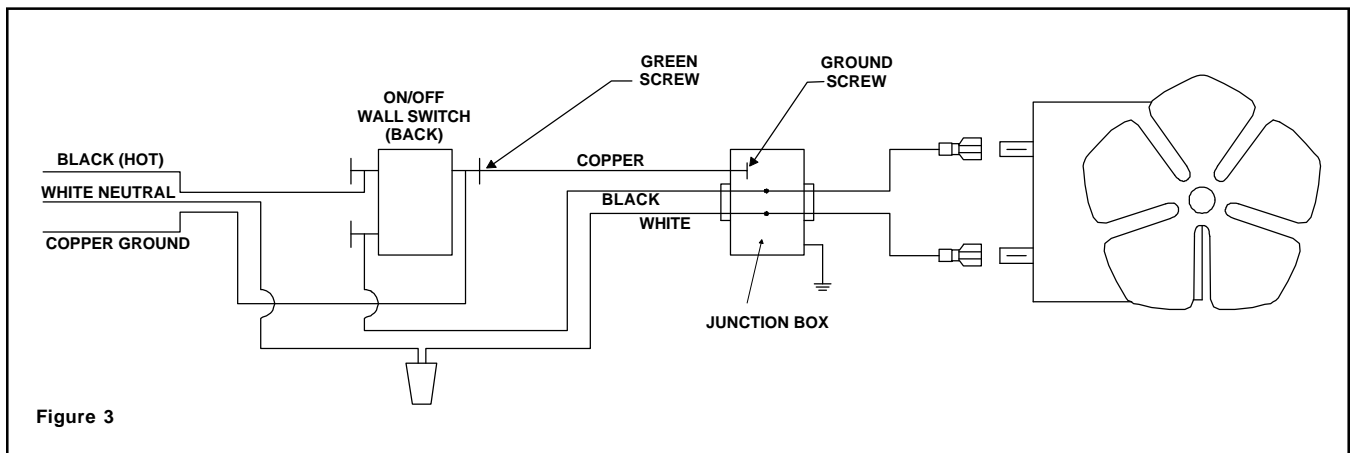

Wire the fan to the wall switch (see Figure 3). Attach the junction box to the fan duct assembly. Use the strain relief to secure the wire through the wall of the junction box.

OPERATION

Turn the switch on to transfer the convection heat for distribution to the whole house. **NOTE:** For maximum distribution effectiveness, turn the furnace fan from the “auto” position to the “on” position.

MAINTENANCE

Service and maintain the gas fireplace per instructions.

Keep the air register(s) clean and free of any blockage.