



ENERGY STAR® QUALIFIED

# Power Vent Water Heaters

GSW ENERGY STAR® Power Vent gas water heaters have been engineered to provide the highest energy efficiency ratings for a water heater of its kind in the market today. The reliable and trouble-free operation of the GSW Power Vent will provide hot water and peace of mind for years to come.

## HIGH QUALITY FEATURES

- ENERGY STAR qualified models, including the only 75 USG ENERGY STAR model available in the market today
- Up to 0.70 Energy Factor
- Exceeds NRCan energy efficiency standards
- Ideal as a replacement water heater in a variety of applications due the 3-position rotatable blower
- Available for Natural Gas or Propane
- Exclusive TankSaver® design to prolong tank life
- Convenient 3/4" side taps for combination applications on 50 USG high-input and 75 USG models
- Suitable for elevations up to 10,100 ft.
- Sensor detects the presence of flammable vapours and automatically disables the unit preventing their ignition
- Robust air intake snorkel inhibits flammable vapours from entering the combustion chamber
- State-of-the-art electronic gas control features advanced self-diagnostic capability that makes troubleshooting easy
- Conveniently located T&P and drain valve for ease of installation, serviceability and maintenance
- Can be vented with 2", 3" or 4" ULC s636 PVC or CPVC or polypropylene pipe up to 180 equivalent feet





ENERGY STAR® QUALIFIED

# Power Vent Water Heaters

## PERFORMANCE

Tank Warranty	Model	Capacity	Maximum Certified Altitude	Input	Recovery Rate at 100°F/55°C Temp. Rise	First Hour Rating	Energy Factor
Years**		USG (L)	ft (m)	BTU/hr	GPH (LPH)	USG (L)	
NATURAL GAS							
6	G640S40N-PV-ES2	40 (151)	10,100 (3,079)	40,000	40 (151)	73 (276)	0.70
6	G640T50N-PV-ES2	40 (151)	10,100 (3,079)	50,000	50 (188)	90 (341)	0.70
6	G650S40N-PV-ES2	50 (189)	10,100 (3,079)	40,000	40 (151)	90 (341)	0.70
6	G650T50N-PV-ES2	50 (189)	10,100 (3,079)	50,000	50 (188)	96 (363)	0.70
6	G650S62N-PV-ES2*	50 (189)	10,100 (3,079)	62,000	62 (233)	110 (416)	0.70
6	G660S42N-PV-ES2	60 (227)	10,100 (3,079)	42,000	42 (159)	106 (401)	0.70
6	G675T72N-PV-ES2*	75 (284)	10,100 (3,079)	72,000	72 (264)	155 (587)	0.68

Propane Models Sub N with P.

\* Model has side connections

\*\*In Residential applications. Reduced warranty in Commercial applications. Parts warranted for 1 year.

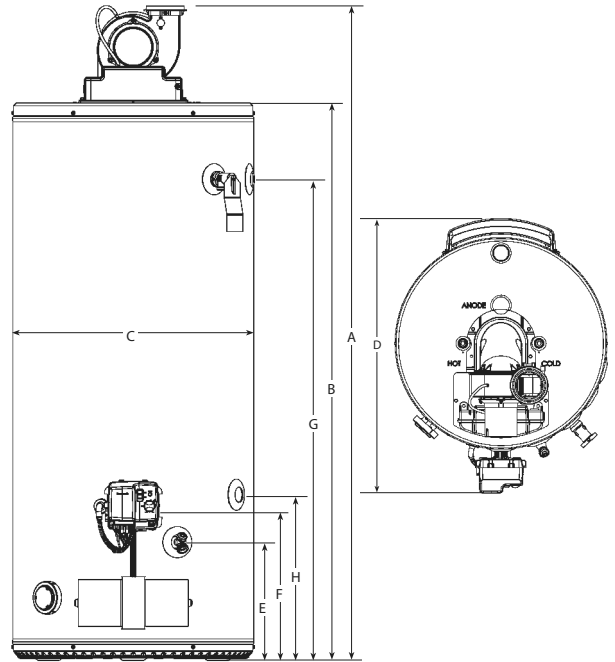

## DIMENSIONS & SHIPPING WEIGHT

Model	Installation Height	Height to Top of Tank	Tank Diameter	Overall Depth	Height to Drain Valve	Height to Gas Inlet	Height to T&P and Upper Side Connection (where applicable)	Height to Lower Side Connection (where applicable)	Approx. Shipping Weight
	A in (cm)	B in (cm)	C in (cm)	D in (cm)	E in (cm)	F in (cm)	G in (cm)	H in (cm)	lb (kg)
G640S40N-PV-ES2	59 (150)	49 3/8 (126)	22 (56)	29 1/8 (74)	11 (28)	14 1/4 (36)	42 1/2 (108)	n/a	174 (79)
G640T50N-PV-ES2	68 1/2 (174)	59 1/4 (150)	20 (51)	27 1/8 (69)	11 (28)	14 1/4 (36)	53 3/8 (135)	15 1/4 (39)	176 (80)
G650S40N-PV-ES2	60 3/8 (153)	50 3/4 (129)	24 (61)	31 1/8 (79)	11 (28)	14 1/4 (36)	43 3/4 (111)	n/a	198 (90)
G650T50N-PV-ES2	68 3/8 (173)	58 3/4 (149)	22 (56)	29 1/8 (74)	11 (28)	14 1/4 (36)	51 3/4 (131)	15 1/4 (39)	192 (87)
G650S62N-PV-ES2*	61 1/8 (155)	52 (132)	24 (61)	31 1/8 (79)	11 (28)	14 1/4 (36)	44 1/2 (113)	15 1/4 (39)	212 (96)
G660S42N-PV-ES2	67 1/4 (171)	57 7/8 (147)	24 (61)	31 1/8 (79)	11 (28)	14 1/4 (36)	50 3/8 (128)	15 1/4 (39)	216 (98)
G675T72N-PV-ES2*	70 3/8 (179)	61 1/4 (156)	26 (66)	33 1/8 (84)	11 (28)	14 1/4 (36)	53 (135)	15 1/4 (39)	277 (126)

## PREFERRED INSTALLATION

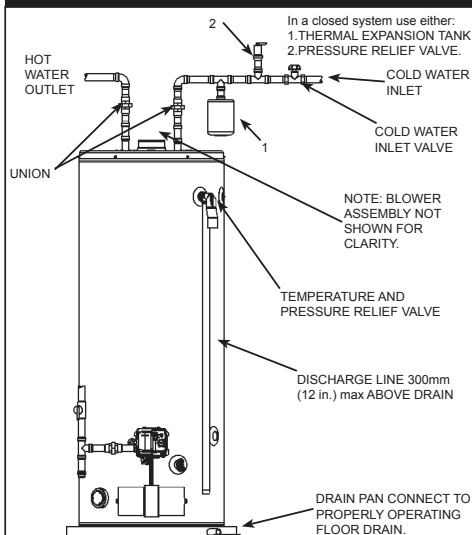

## VENT PIPE LENGTHS

Model	Vent Pipe Diameter in	Minimum Number of Elbows Required*	Maximum Vent Length with one 90° Elbow ft (m)	Minimum Vent Length with one 90° Elbow ft (m)
40S40	2	0	50 (15.2)	7 (2.1)
40T50				
50S40	3	0	125 (38.1)	50 (15.2)
50T50				
60S42	4	0	180 (54.9)	125 (38.1)
50S62	3	0	50 (15.2)	7 (2.1)
75T72	4	0	125 (38.1)	50 (15.2)

\* Refer to installation manual for further details.

## ACCESSORY KITS

Description	Part Number
3" Vent Kit Includes coupling for blower outlet and termination screens	9008311005
4" Vent Termination Kit Includes termination screens	9008310015