

Quiet, reliable and efficient operation in a quality design: the GSW Direct Vent water heater. The balanced flue design with a side wall vent termination allows installation in locations without a chimney. The sealed combustion chamber and co-axial vent uses fresh air taken from outside rather than compromising indoor air quality. Ideal for applications where space is at a premium.

HIGH QUALITY FEATURES

- Thermopile design provides robust pilot to withstand down drafts and environmental conditions
- LED indicator:
 - Gives visual confirmation that pilot is on by flashing continuously
 - Provides diagnostics and troubleshooting
- Easy temperature adjustments
- Direct vent design means no external power supply or chimney required for operation/installation
- 90" Coaxial vent supplied with water heater
- Top mounted heavy duty anode rod for added tank protection
- Glass-lined tank for longer life
- Factory-installed plastic-lined nipples with heat traps
- CFC-free foam insulation
- Suitable for closet installations due to direct vent design not requiring an external power supply
- Sealed combustion chamber design, eliminating the need for Flammable Vapour sensor
- Combustion chamber is easy to access
- Conveniently located T&P and drain valve for ease of installation and maintenance





Direct Vent Gas Water Heaters

PERFORMANCE

Tank Warranty**	Model	Capacity	Maximum Certified Altitude	Input	Recovery Rate at 100°F/55°C Temp. Rise	First Hour Rating	Energy Factor
Years							
NATURAL GAS							
6	6G40BFNA-FV Series 10	40 (151)	5,400 (1,646)	38,000	34 (129)	73 (286)	0.59
6	6G50TFNA-FV Series 10	50 (189)	5,400 (1,646)	42,000	38 (144)	87 (329)	0.58
PROPANE							
6	6G40BFP-FV Series 11	40 (151)	5,400 (1,546)	38,000	34 (129)	73 (286)	0.59
6	6G50TFBP-FV Series 11	50 (189)	5,400 (1,646)	42,000	38 (144)	87 (329)	0.58

**In Residential applications. Reduced warranty in Commercial applications. Parts warranted for 1 year.

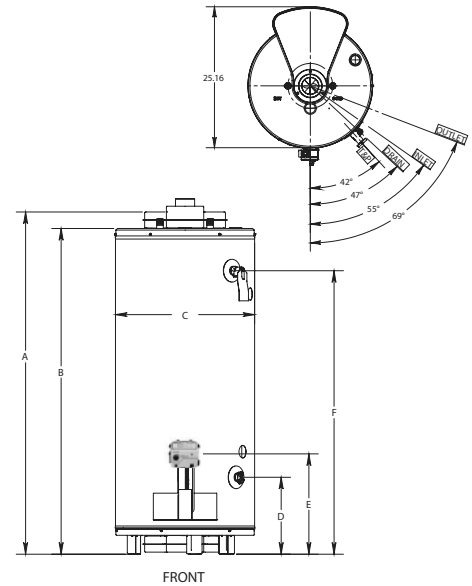

DIMENSIONS & SHIPPING WEIGHT

Model	Installation Height	Height to Top of Tank	Tank Diameter	Height to Drain Valve	Height to Gas Inlet	Height to T&P Valve	Approx. Shipping Weight
	A in (cm)	B in (cm)	C in (cm)	D in (cm)	E in (cm)	F in (cm)	
NATURAL GAS							
6G40BFNA-FV Series 10	56 3/4 (144)	52 (132)	22 1/4 (57)	12 1/4 (31)	16 (40)	45 1/4 (114)	167 (76)
6G50TFNA-FV Series 10	65 3/4 (167)	61 (155)	22 1/4 (57)	12 1/4 (31)	16 (40)	54 (137)	185 (84)
PROPANE							
6G40BFP-FV Series 11	56 3/4 (144)	52 (132)	22 1/4 (57)	12 1/4 (31)	16 (40)	45 1/4 (114)	167 (76)
6G50TFBP-FV Series 11	65 3/4 (167)	61 (155)	22 1/4 (57)	12 1/4 (31)	16 (40)	54 (137)	185 (84)

PREFERRED INSTALLATION

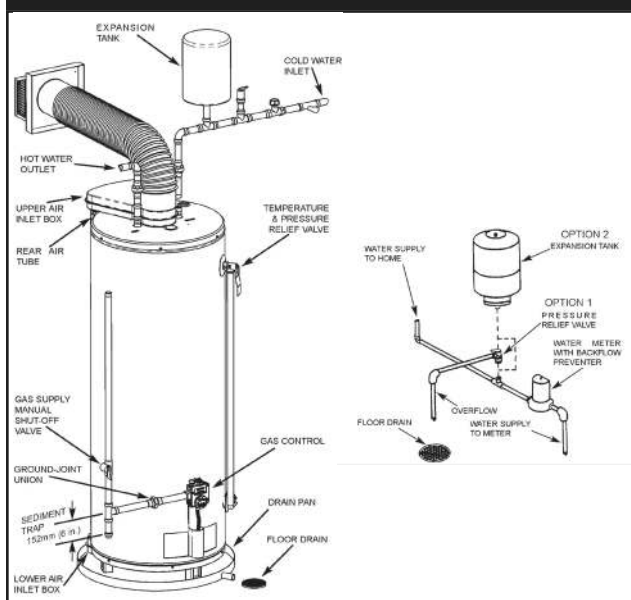

VENT LENGTHS

