

Quiet, reliable and efficient operation in a quality design: the GSW Direct Vent water heater. The balanced flue design with a side wall vent termination allows installation in locations without a chimney. The sealed combustion chamber and co-axial vent uses fresh air taken from outside rather than compromising indoor air quality. Ideal for applications where space is at a premium.

HIGH QUALITY FEATURES

- Thermopile design provides robust pilot to withstand down drafts and environmental conditions
- LED indicator:
 - Gives visual confirmation that pilot is on by flashing continuously
 - Provides diagnostics and troubleshooting
- Easy temperature adjustments
- Direct vent design means no external power supply or chimney required for operation/installation
- 90" Coaxial vent supplied with water heater
- Top mounted heavy duty anode rod for added tank protection
- Glass-lined tank for longer life
- Factory-installed plastic-lined nipples with heat traps
- CFC-free foam insulation
- Suitable for closet installations due to direct vent design not requiring an external power supply
- Sealed combustion chamber design, eliminating the need for Flammable Vapour sensor
- Combustion chamber is easy to access
- Conveniently located T&P and drain valve for ease of installation and maintenance





Direct Vent Gas Water Heaters

PERFORMANCE

| Tank Warranty** | Model | Capacity | Maximum Certified Altitude | Input | Recovery Rate at 100°F/55°C Temp. Rise | First Hour Rating | Energy Factor |
|-----------------|-----------------------|----------|----------------------------|--------|--|-------------------|---------------|
| Years | | | | | | | |
| NATURAL GAS | | | | | | | |
| 6 | 6G40BFNA-FV Series 10 | 40 (151) | 5,400 (1,646) | 38,000 | 34 (129) | 73 (286) | 0.59 |
| 6 | 6G50TFNA-FV Series 10 | 50 (189) | 5,400 (1,646) | 42,000 | 38 (144) | 87 (329) | 0.58 |
| PROPANE | | | | | | | |
| 6 | 6G40BFP-FV Series 11 | 40 (151) | 5,400 (1,546) | 38,000 | 34 (129) | 73 (286) | 0.59 |
| 6 | 6G50TFBP-FV Series 11 | 50 (189) | 5,400 (1,646) | 42,000 | 38 (144) | 87 (329) | 0.58 |

**In Residential applications. Reduced warranty in Commercial applications. Parts warranted for 1 year.

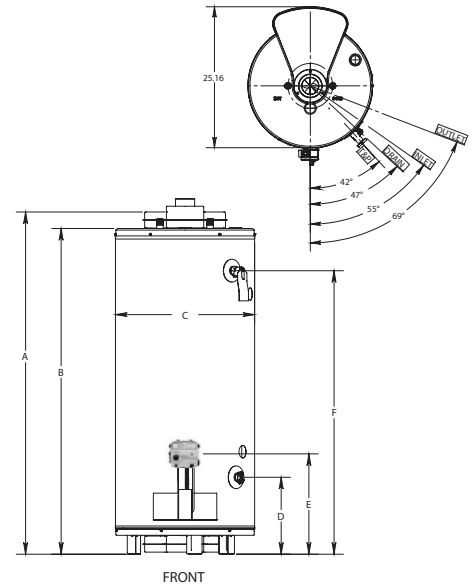

DIMENSIONS & SHIPPING WEIGHT

| Model | Installation Height | Height to Top of Tank | Tank Diameter | Height to Drain Valve | Height to Gas Inlet | Height to T&P Valve | Approx. Shipping Weight |
|-----------------------|---------------------|-----------------------|---------------|-----------------------|---------------------|---------------------|-------------------------|
| | A in (cm) | B in (cm) | C in (cm) | D in (cm) | E in (cm) | F in (cm) | lb (kg) |
| NATURAL GAS | | | | | | | |
| 6G40BFNA-FV Series 10 | 56 3/4 (144) | 52 (132) | 22 1/4 (57) | 12 1/4 (31) | 16 (40) | 45 1/4 (114) | 167 (76) |
| 6G50TFNA-FV Series 10 | 65 3/4 (167) | 61 (155) | 22 1/4 (57) | 12 1/4 (31) | 16 (40) | 54 (137) | 185 (84) |
| PROPANE | | | | | | | |
| 6G40BFP-FV Series 11 | 56 3/4 (144) | 52 (132) | 22 1/4 (57) | 12 1/4 (31) | 16 (40) | 45 1/4 (114) | 167 (76) |
| 6G50TFBP-FV Series 11 | 65 3/4 (167) | 61 (155) | 22 1/4 (57) | 12 1/4 (31) | 16 (40) | 54 (137) | 185 (84) |

PREFERRED INSTALLATION

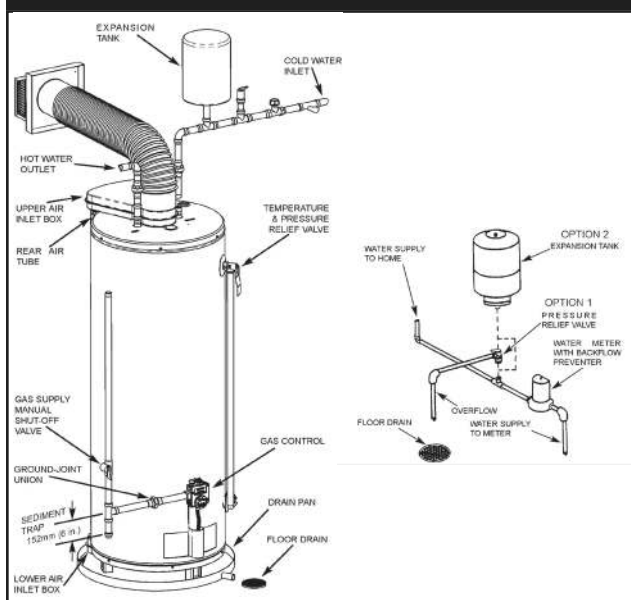

VENT LENGTHS

