

Combi1™ TTW®

Residential Power Vent Combi1™ TTW® Energy Saver Gas Water Heater System



Photo is of
C-SW2-TW50T10FBN

FEATURING:



The Combi1™ TTW® FVIR Defender Safety System® Models Feature (50T model, only):

- **Advanced ScreenLok® Technology Flame Arrestor Design**—Flame arrestor is designed to prevent ignition of flammable vapor outside of the water heater.
- **Flammable Vapor Sensor**—Electronic sensor prevents burner operation if flammable vapors are detected. The sensor will also prevent operation if there is ongoing flammable vapor burn inside the combustion chamber.
- **Maintenance Free**—Regular cleaning of air inlet openings or flame arrestor is not required under normal conditions.
- **Sight Window**—Offers a view of the pilot and burner operation.

All Combi1™ TTW® Models Feature

- **Internal Single Wall Heat Exchanger**—1½" O.D. glass coated (Vitraglas®) steel coil.
 - 1" NPT Solar Collector Supply and Return Connections.
- **Low Heat Exchanger Head Loss**—Up to 10 GPM flow, with less than 5 ft. of head loss. Greatly reduces the required pump size for heat exchange.
- **Integrated Mixing Device**—Features an accurate, easy to use hand wheel for adjusting mixed water temperature, a pre-piped stainless steel flexible connector for quick installation as well as optional water connections (1/2" NPT recirculation inlet, 1/2" NPT hot water outlet, 1/4" NPT cold water outlet). This required system is easily installed and ensures a comfortable outlet temperature while providing a steady flow of hot water.
- **Honeywell Self Diagnostic Electronic Gas Control** —Intelligent gas control with spark to pilot ignition system eliminates the constant burning pilot. This results in savings of pilot gas during stand by periods (120 V.A.C.).
 - **Enhanced Performance**—Proprietary algorithms provide enhanced First Hour Delivery ratings and tighter temperature differentials.
 - **Advanced Temperature Control System**—Microprocessor constantly monitors and controls burner operation to maintain accurate water temperature levels.
 - **Intelligent Diagnostics**—An exclusive green LED light prompts the installer during start-up and provides ten different diagnostic codes to assist in troubleshooting.
- **Factory installed Hydrojet® 2™ Total Performance System**—Cold water inlet sediment reducing device helps prevent sediment build up in tank. Increases first hour delivery and minimizing temperature build up in tank.
- **Vitraglas® Lining**—Bradford White tanks are lined with an exclusively engineered enamel formula that provides superior tank protection from the highly corrosive effects of hot water. This formula (Vitraglas®) is fused to the steel surface by firing at a temperature of over 1600°F (871°C).
- **Horizontal and Vertical Venting**—With 3" or 4" PVC, ABS OR CPVC (Maximum equivalent vent lengths on reverse side).
- **2" Non-CFC Foam Insulation**—Covers the sides and top of tank, reducing the amount of heat loss. This results in less energy consumption, improved operation efficiencies and jacket rigidity.
- **Pedestal Base.**
- **Water Connections**—3/4" NPT factory installed true dielectric fittings.
- **Two Protective Anode Rods.**
- **T&P Relief Valve**—Installed.
- **Low Restriction Brass Drain Valve**—Durable tamper proof design.

10-Year Limited Tank and Heat Exchanger Warranties / 6-Year Limited Warranty on Component Parts.

For more information on warranty, please visit www.bradfordwhite.com

For products installed in USA, Canada and Puerto Rico. Some states do not allow limitations on warranties. See complete copy of the warranty included with the heater.



Residential Power Vent Gas Water Heater System

Combi1™ TTW® Energy Saver Models

NATURAL GAS AND LIQUID PROPANE GAS

Meet or exceed ASHRAE 90.1b (current standard) C.E.C. Listed
80% Recovery Efficiency

Model Number	Capacity				Recovery 90°F Rise*				A	B	C	D	E	F	G	H	J	K	Approx. Shipping Weight
	U.S. Gal.	Imp. Gal.	Nat. BTU/Hr. Input	LP BTU/Hr. Input	Nat. U.S. GPH	Imp. U.S. GPH	LP U.S. GPH	LP Imp. GPH	Floor to Vent Conn. in.	Jacket Dia. in.	Vent Size in.	Floor to T&P Conn. in.	Floor to Gas Conn. in.	Floor to Exchanger Inlet in.	Floor to Exchanger Outlet in.	Floor to Heater Top in.	Floor to Water Conn. in.	Depth in.	
C-SW2-TW50T10FBN	45	38	67,000	60,000	72	60	65	54	65%	22	3	50%	11%	31½	50	56%	60%	26%	243
C-SW2-TW75T10BN	72	61	76,000	75,500	82	69	81	67	68%	26	3	53	15	34½	53	60%	64%	31	313

Model Number	Capacity				Recovery 50°C Rise*		A	B	C	D	E	F	G	H	J	K	Approx. Shipping Weight
	Liters	kW Input	Nat. kW Input	LP kW Input	Nat. Liters/Hour	LP Liters/Hour	Floor to Vent Conn. mm.	Jacket Dia. mm.	Vent Size mm.	Floor to T&P Conn. mm.	Floor to Gas Conn. mm.	Floor to Exchanger Inlet mm.	Floor to Exchanger Outlet mm.	Floor to Heater Top mm.	Floor to Water Conn. mm.	Depth mm.	
C-SW2-TW50T10FBN	170	19.6	17.5	272	246	1673	559	76	1273	298	786	1270	1432	1543	679	110	
C-SW2-TW75T10BN	272	22.3	22.1	310	306	1737	660	76	1346	389	868	1549	1530	1632	787	142	

Propane models feature a Titanium Stainless Steel propane burner. For Propane (LP) models change suffix "BN" to "SX".

*Based on manufacturers rated recovery efficiency.

110 V.A.C Required for Power Venting / 110 V.A.C., 60HZ, 3.1 Amperes.

CAEF is .65 (TW50) and .64(TW75)

CAAFUE% is 82.0

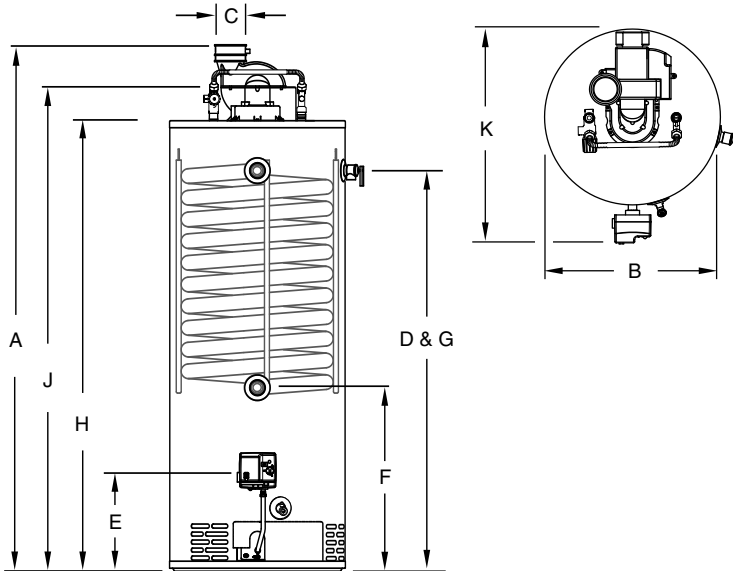

Heat Exchanger Head Loss	
GPM	Ft. of Hd. Loss
2	0.03
5	0.20
8	0.51
10	0.80
12	1.15

	C-SW2-TW50T	C-SW2-TW75T	3" Vent Pipe	4" Vent Pipe
Max. Equivalent Length			†60 ft.**	†180 ft.
Min. Equivalent Length			7 ft.	15 ft.
Number of 90° Elbows			1 55 ft. 2 50 ft. 3 45 ft.	1 175 ft. 2 170 ft. 3 165 ft.

Subtract 5ft. for each additional 90° elbow.

†For high altitude installations, consult the installation instructions.

**C-SW2-TW75T maximum 3" vent length is 50ft.

Heat Exchanger Values*

Supply Temperature	140°F	120°F	100°F
Return Temperature	120°F	100°F	80°F
Differential	20°F	20°F	20°F
Flow Rate (50 Gal.)	4.1 GPM	4.6 GPM	4.6 GPM
Net Output (50 Gal.)	35,000 BTU/Hr.	39,500 BTU/Hr.	39,500 BTU/Hr.
Flow Rate (75 Gal.)	4.1 GPM	5.6 GPM	5.6 GPM
Net Output (75 Gal.)	35,000 BTU/Hr.	47,500 BTU/Hr.	47,500 BTU/Hr.

*These values were obtained using 180°F stored tank temperature.

Net Output is the space heating capacity based on normal piping and pickup allowance of 15%.

Actual values may vary based on circulator flow rate, number of zones, water and space heating demands. Numbers subject to change.

Meets NAECA Requirements

General

All gas water heaters are certified at 300 PSI test pressure (2068 kPa) and 150 PSI working pressure (1034 kPa). All potable water connections are 3/4" NPT (19mm) on 11" (203) centers. All heat exchanger connections are 1" NPT (25mm). All gas connections 1/2" (13mm).

All models design certified by CSA International (formerly AGA/CGA), ANSI Z-21.10.1 and or 10.3 and peak performance rated.

Dimensions and specifications subject to change without notice in accordance with our policy of continuous product improvement.

Suitable for Water (Potable) Heating and Space Heating.

Toxic chemicals, such as those used for boiler treatment, shall NEVER be introduced into the potable water side. The potable side of this unit may NEVER be connected to any existing heating system or component(s) previously used with a non-potable water heating appliance. The heat exchanger side of the unit may be used in space heating applications.



For U.S. and Canada field service, contact your professional installer or local Bradford White sales representative.

Sales 800-523-2931 • Fax 215-641-1670 / Technical Support 800-334-3393 • Fax 269-795-1089 • Warranty 800-531-2111 • Fax 269-795-1089

International: Telephone 215-641-9400 • Telefax 215-641-9750 / www.bradfordwhite.com

BRADFORD WHITE-CANADA INC. Sales / Technical Support 866-690-0961 / 905-238-0100 • Fax 905-238-0105 / www.bradfordwhite.com

Built to be the Best™

©2014, Bradford White Corporation. All rights reserved.