

**Models:**  
**SLP Venting System**



These venting system components have been tested for use with approved HHT Direct Vent appliances. Check with your local building code agency before you begin installation to ensure compliance with local codes, including the need for permits and follow-up inspections. If you encounter any problems regarding code approvals, or if you need clarification of any of the instructions contained here, contact your Hearth & Home Technologies Inc. dealer. For the dealer nearest you, please visit [www.hearthnhome.com](http://www.hearthnhome.com).

**Important Notice: Align the seams of the pipe sections to allow engagement. Rotate the vent component to lock into place. Use this procedure for all vent components. See Figure 13.**

**Important Notice: SLP venting systems can be used without an adapter on appliances with SL-D style starting collars. Two screws are required to attach the first piece of SLP venting to the SL-D style starting collar.**

**CAUTION! Risk of Cuts/Abrasions.** Wear protective gloves and safety glasses during installation. Sheet metal edges are sharp.

## A. Pipe Clearances to Combustibles

**WARNING! Risk of Fire!** Maintain air space clearance to vent. **DO NOT** pack insulation or other combustibles:

- Between ceiling firestops
- Between wall shield firestops
- Around vent system

Failure to keep insulation or other material away from vent pipe may cause over heating and fire.

Refer to appliance installation manuals for clearances.

## B. Wall Penetration Framing

- Wherever a combustible wall is penetrated, the hole must be framed and a wall shield (with attached heat shield) installed on both sides. These shields maintain minimum clearances and restrict cold air infiltration.
- If the wall being penetrated is of noncombustible materials (material which will not ignite or burn, or has a UL fire rating of zero), a hole 1 in. (25 mm) larger in diameter than the pipe is acceptable.

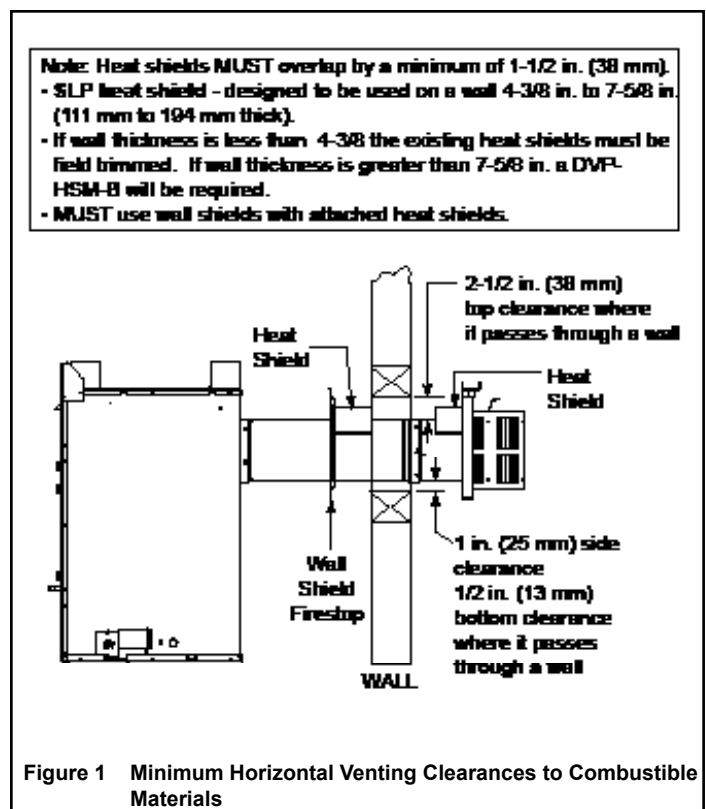

### C. Install the Ceiling Firestop

- Frame an opening 9 in. x 9 in. (229 mm x 229 mm) whenever the vent system penetrates a ceiling/floor (see Figure 2)
- Frame the area with the same sized lumber as used in ceiling/floor joist.
- When installing a top vent vertical termination appliance the hole should be directly above the appliance, unless the flue is offset.
- The ceiling firestop may be installed above or below the ceiling. Refer to Figure 3.
- Secure with three fasteners on each side.
- Do not pack insulation around the pipe. Insulation must be kept away from the pipe.

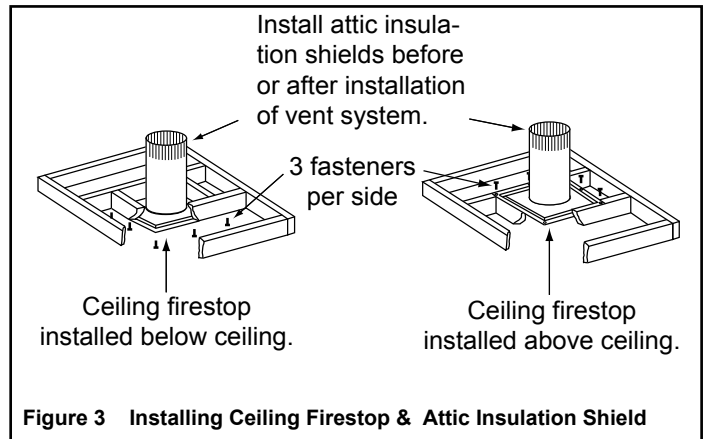
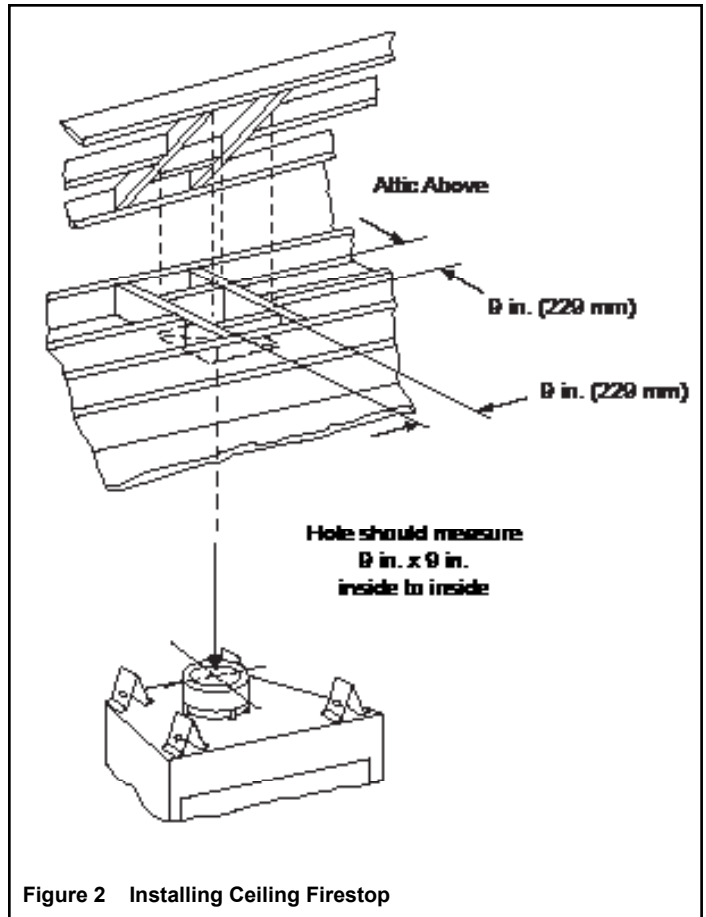

## D. Install Attic Insulation Shield

**WARNING! Fire Risk. DO NOT** allow loose materials or insulation to touch vent. Hearth & Home Technologies Inc. requires the use of an attic shield.

The National Fuel Gas Code ANSI Z223.1 requires an attic shield constructed of 26 gauge minimum metal that extends at least 2 in. (51 mm) above insulation.

Attic shields must meet specified clearance and be secured in place.

### Flat Ceiling Installation

- Remove one shield from box.  
**Note:** Cut previously installed batt insulation to make room for the attic insulation shield.
- Wrap shield around pipe if pipe is already installed in area to be insulated.
- Match the three holes in each side and fasten with three screws to form a tube.
- One or more tabs may be folded outward on the bottom of the shield to allow attachment to ceiling firestop.
- Bend remaining tabs inward on bottom of shield where it rests on the ceiling firestop to maintain the air space between the pipe and shield. Set the shield on the ceiling firestop.
- Bend all tabs inward 90° around the top of the shield. These tabs must be used to prevent blow-in insulation from getting between the shield and vent pipe, and to maintain clearance.

### Vaulted Ceiling Installation

- The attic insulation shield has been laser-etched with cut lines and ceiling pitches to make field trimming easier.
- Remove one shield from box.  
**Note:** Cut previously installed batt insulation to make room for the attic insulation shield.
- Cut the attic insulation shield (if application is for vaulted ceiling) using a laser-etched cut line, to fit your ceiling pitch. Snip cut edge to create three bend tabs.
- Wrap shield around pipe if pipe is already installed in area to be insulated.
- Match the three holes in each side and fasten with three screws to form a tube.
- One or more tabs may be folded outward on the bottom of the shield to allow attachment to ceiling firestop.
- Bend remaining tabs inward on bottom of shield where it rests on the ceiling firestop to maintain the air space between the pipe and shield. Set the shield on the ceiling firestop.
- Bend all tabs inward 90° around the top of the shield. These tabs must be used to prevent blow-in insulation from getting between the shield and vent pipe, and to maintain clearance.

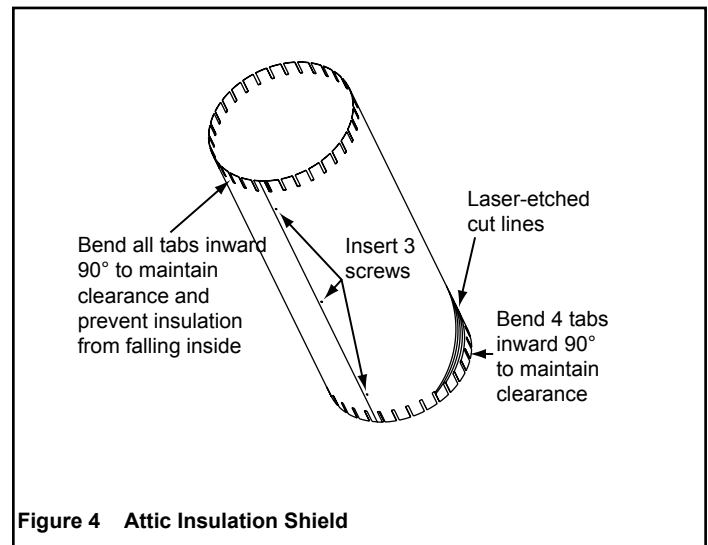

## E. Assemble SLP Vent Sections

**WARNING! Risk of Fire/Explosion/Asphyxiation!** Improper support may allow vent to sag and separate. Use vent run supports and connect vent sections per installation instructions. **DO NOT** allow vent to sag below connection point to appliance.

**Note:** Two 1/2 in. screws are required to attach the first piece of SLP venting to SL-D style starting collars.

- SLP venting systems can be used without an adapter on appliances which have SL-D style starting collars.



Figure 5 SLP Pipe onto SL-D Collar

- Slide the first section of vent over the SL-D collar and push down until all six dimples on the vent lock onto the SL-D collar.
- Secure the first vent section to the collar with two 1/2 in. screws using the dimples as guides for screws.

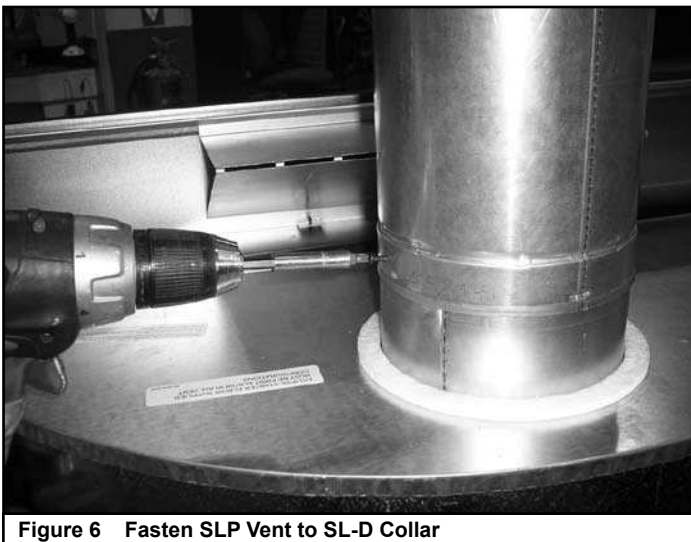

Figure 6 Fasten SLP Vent to SL-D Collar



Figure 7 Fasten SLP Vent to Stove

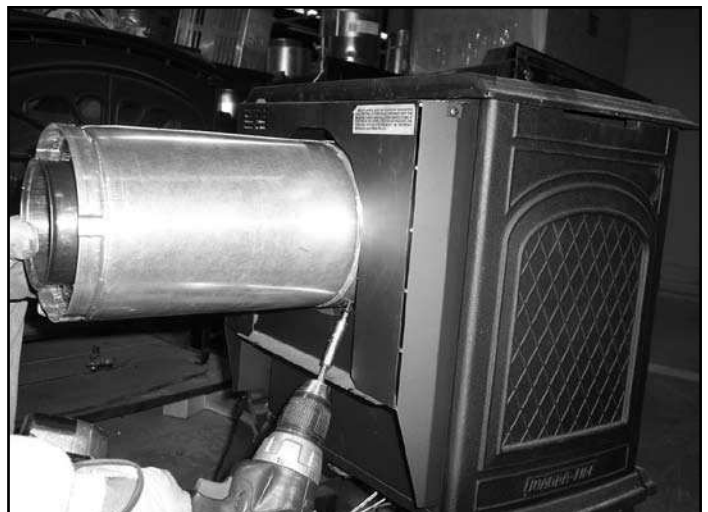

Figure 8 Fasten SLP Vent to Rear Vent

- SL Series Fireplaces: Insert one 1/2 in. screw through the dimple on the heat shield into the first vent section. See Figure 9.

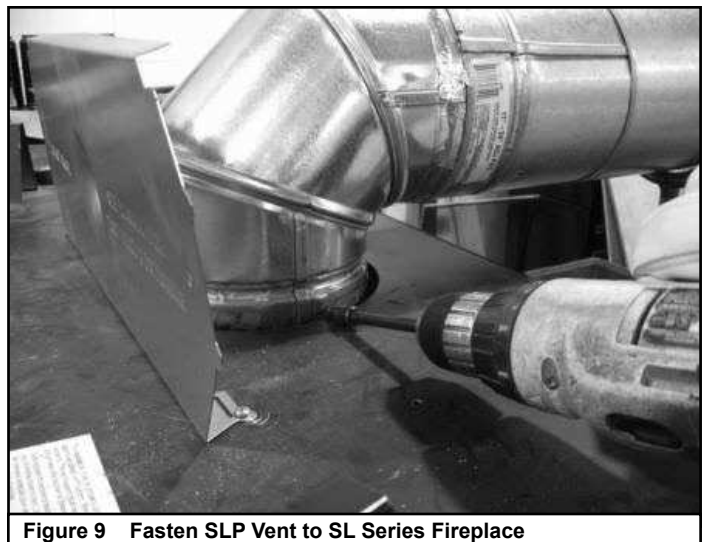

Figure 9 Fasten SLP Vent to SL Series Fireplace

- Top-Vent Stoves only: An SLP-SAM is required to adapt the inner flue to SLP vent. No adapter is needed on the outer flue. See Figures 10 and 11.



Figure 10 Remove SL-D Adapter



Figure 11 Install SLP-SAM Adapter

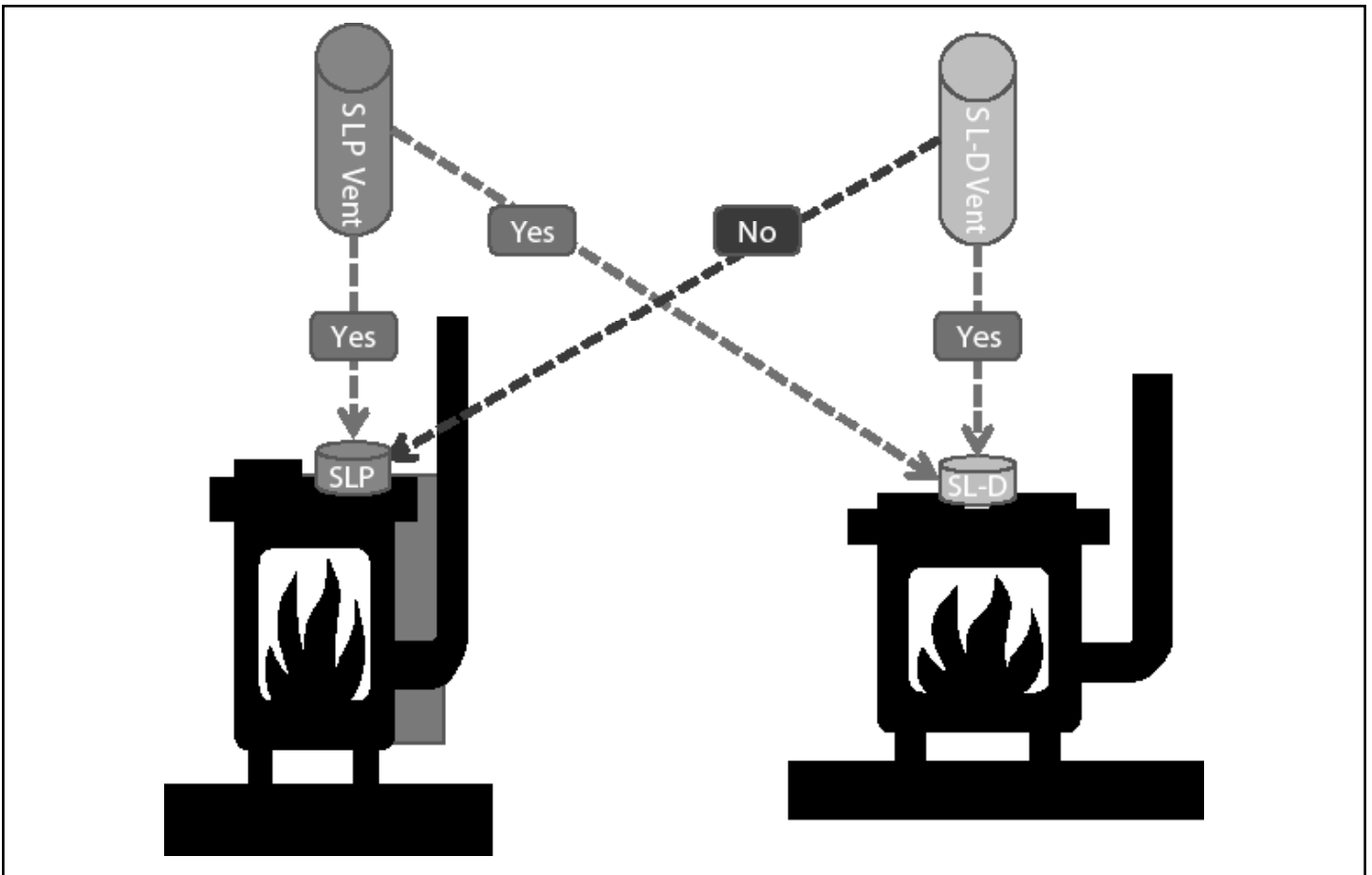
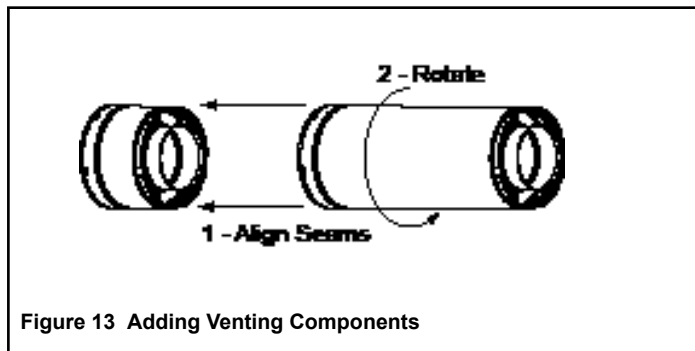

Figure 12 Quick Pipe-to-Collar Reference for Fireplaces and Stoves

### Attach the First Vent Component to SLP Starting Collars

To attach the first vent component to the starting collars of the appliance:

- Lock the vent components into place by sliding the pipe section onto the collar.
- Align the seam of the pipe and seam of collar to allow engagement. Rotate the vent component to lock into place. Use this procedure for all vent components. See Figure 13.
- Slide the ceramic fiber pad over the first vent section and place it flush to the appliance. This will prevent cold air infiltration. High temperature caulk may be used to hold the part in place. Continue to add vent components.
- Continue adding vent components, locking each succeeding component into place.
- Ensure that each succeeding vent component is securely fitted and locked into the preceding component.



**Note:** The end of the pipe sections with the lances/tabs on it will face toward the appliance.

### Commercial, Multi-family (multi-level exceeding two stories), or High-rise Applications

For installation into a commercial, multi-family (multi-level exceeding two stories), or high-rise application: All outer pipe joints must be sealed with high temperature silicone, including the slip section that connects directly to the horizontal termination cap.

- Apply a bead of silicone sealant inside the female outer pipe joint prior to joining sections. See Figure 14.
- Only outer pipes are to be sealed. Do not seal the inner flue. All unit collar, pipe, slip section, elbow and cap outer flues shall be sealed in this manner, unless otherwise stated.

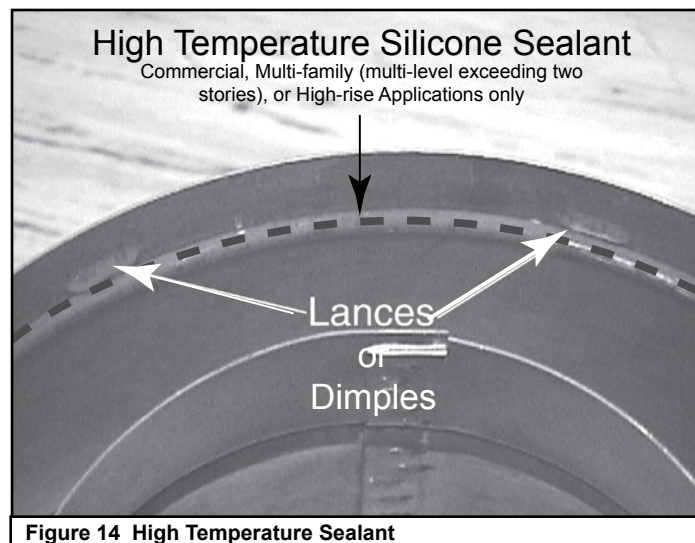

## F. Additional Assembly Instructions DVP & SLP Vent Pipe

### Assemble Slip Sections

The outer flue of the slip section should slide over the outer flue of the pipe section and into (inner flue) the last pipe section (see Figure 16).

Slide together to the desired length, making sure that a 1-1/2 in. outer flue overlap is maintained between the pipe section and slip section.

The pipe and slip section need to be secured by driving two 1/2 in. screws through the overlapping portions of the outer flues using the pilot holes (see Figure 17).

This will secure the slip section to the desired length and prevent it from separating. The slip section can then be attached to the next pipe section.

If the slip section is too long, the inner and outer flues of the slip section can be cut to the desired length.

**WARNING! Risk of Fire/Explosion! DO NOT break silicone seals on slip sections. Use care when removing termination cap from slip pipe. If slip section seals are broken during removal of the termination cap, vent may leak.**

**Note:** When installing a vent system with an HRC termination cap, all pipe system joints shall be sealed using a high-temperature silicone sealant.

- Apply a bead of silicone sealant inside the female outer pipe joint prior to joining sections.
- Only outer pipes are sealed, sealing the inner flue is not required. All unit collar, pipe, slip section, elbow and cap outer flues shall be sealed in this manner.

Check appliance installation instructions for approval with HRC Series Cap.

Make sure the seams are not aligned to prevent unintentional disconnection.

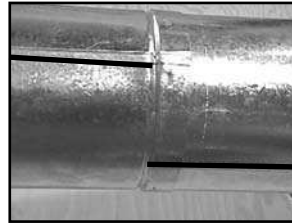

CORRECT

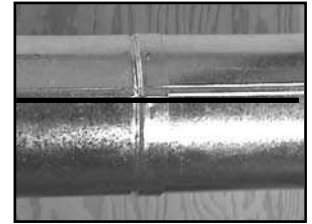

INCORRECT

Figure 15 Seams

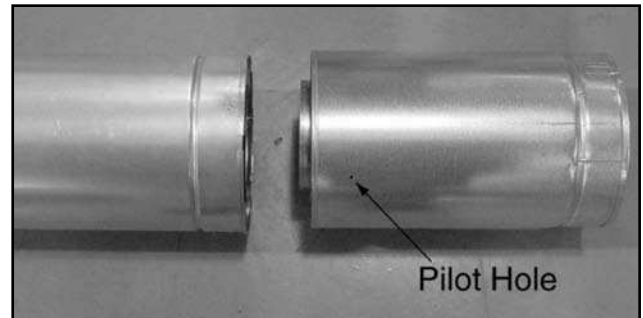

Figure 16 Slip Section Pilot Holes

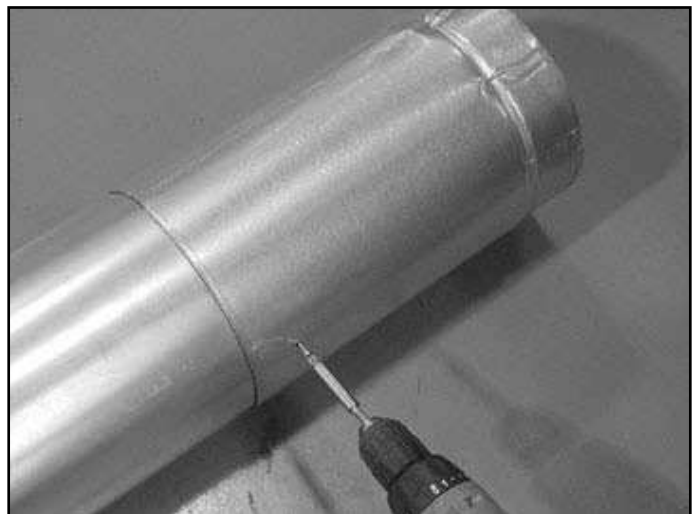

Figure 17 Screws into Slip Section

## Secure the Vent Sections

Vertical sections of SLP pipe must be supported every 8 ft.

The SLP firestop includes tabs that may be used to secure vertical sections.

The vent support or plumber's strap (spaced 120° apart) may be used to secure the vertical sections of pipe (see Figure 18).

Horizontal sections of vent must be supported every 5 ft with a vent support or plumber's strap (see Figure 19).

**WARNING! Risk of Fire/Explosion/Asphyxiation!** Improper support may allow vent to sag and separate. Use vent run supports and connect vent sections per installation instructions. **DO NOT** allow vent to sag below connection point to appliance.

## G. Disassemble Vent Sections

To disassemble any two pieces of pipe, rotate either section (Figure 20), so that the seams on both pipe sections are aligned (Figure 21). They can then be carefully pulled apart.

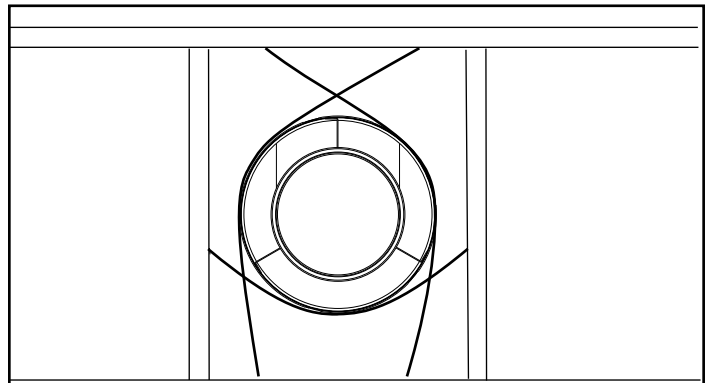

Figure 18 Securing Vertical Pipe Sections

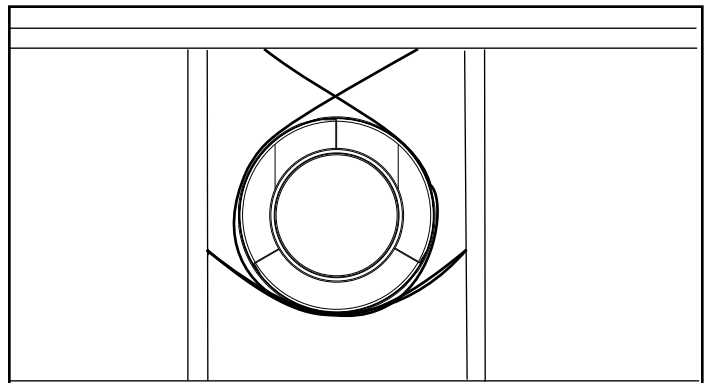

Figure 19 Securing Horizontal Pipe Sections

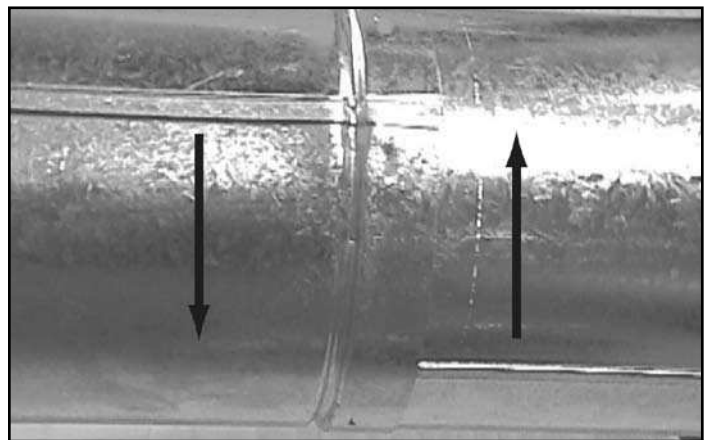

Figure 20 Rotate Seams for Disassembly

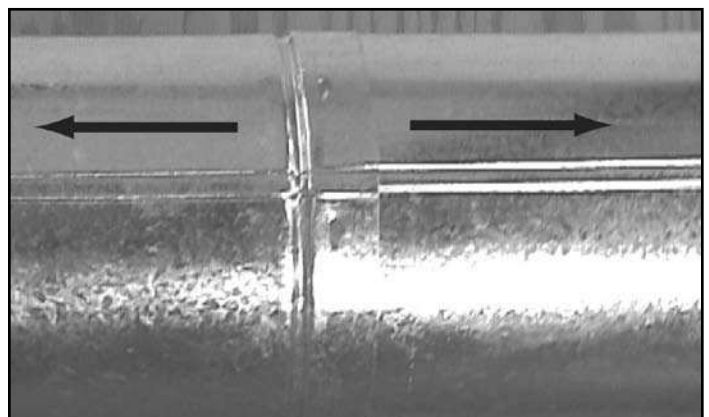

Figure 21 Align and Disassemble Vent Sections



## H. Install the Heat Shield and Horizontal Termination Cap

**WARNING! Risk of Fire!** The telescoping flue section of the termination cap **MUST** be used when connecting vent.

- 1-1/2 (38 mm) minimum overlap of vent and telescoping flue section is required.

Failure to maintain overlap may cause overheating and fire.

**Note:** For horizontal vent runs through a combustible wall and framing dimensions, refer to appliance installation manual.

### Heat Shield Requirements for Horizontal Termination

For all horizontally terminated appliances, a heat shield **MUST** be placed 1 in. above the top of the vent between the wall shield firestop and the base of the termination cap.

There are two sections of the heat shield. One section is factory-attached to the wall shield firestop. The other section is factory-attached to the cap. See Figure 8.13.

**WARNING! Risk of Fire!** To prevent overheating and fire, heat shields must extend through the entire wall thickness. Heat shields must overlap 1-1/2 in. (38 mm) minimum.

If the wall thickness does not allow the required 1-1/2 in. (38 mm) heat shield overlap when installed, an extended heat shield must be used.

If the wall thickness is less than 4-3/8 in./111 mm, the heat shields on the cap and wall shield firestop will need to be trimmed. A minimum 1-1/2 overlap **MUST** be maintained.

**NOTICE:** Heat shields may not be field constructed.

The extended heat shield may need to be cut to length. You will attach the cut heat shield to the existing cap heat shield or wall shield firestop heat shield using the supplied screws.

You **MUST** maintain a 1-1/2 in. (38 mm) overlap of the extended heat shield and the existing shields (both ends of the heat shield). The small leg on the extended heat shield should rest on the top of the vent (pipe section) to properly space it from the pipe section.

## Install the Horizontal Termination Cap

Attach slip section of cap to last vent section. Maintain 1-1/2 in. overlap between slip and vent sections.

**Note:** For installations using black pipe, slide the decorative wall thimble over the last vent pipe before connecting the termination to the pipe. When this connection has been made, slide the wall thimble up to the interior wall surface and attach with screws provided.

Secure termination cap to exterior wall using provided holes and fasteners.

Vent termination must not be recessed in the wall. Siding may be brought to the edge of the cap base.

**Note:** When using termination caps with a factory-supplied heat shield attached, no additional wall shield firestop is required on the exterior side of a combustible wall.

**CAUTION! Risk of Burns!** Local codes may require installation of a cap shield to prevent anything or anyone from touching the hot cap.

Flash and seal as appropriate for siding material at outside edges of cap.

When installing a horizontal termination cap, follow the cap location guidelines as prescribed by current **ANSI Z223.1** and **CAN/CGA-B149** installation codes.

**Note:** Where required, an exterior wall flashing is available. When penetrating a brick wall, a brick extension kit is available for framing the brick.

## I. Installing Decorative Ceiling Components

A black painted decorative ceiling thimble can be installed on a flat ceiling through which the vent passes. The ceiling thimble is used to cover the firestop.

- Seal the gap between the vent pipe and firestop using high temperature silicone to prevent cold air infiltration.
- Install the decorative ceiling thimble by sliding it up to the ceiling and attaching it using the provided screws.

A decorative black cathedral ceiling support box can be used where vertical vent runs pass through a cathedral ceiling.

- Use a plumb-bob to mark the centerline of the venting system on the ceiling and drill a small hole through the ceiling and roof at this point. Locate the hole and mark the outline of the cathedral ceiling support box on the outside roof.
- Remove shingles or other roof covering as necessary to cut the rectangular hole for the support box. Cut this hole 1/8 in. (3 mm) larger than the marked outline.
- Lower the support box through the hole until its bottom is at least 2 in. (51 mm) below the ceiling. See Figure 22.
- Level the support box both vertically and horizontally and temporarily tack it in place through the inside walls into the roof sheathing.
- Use tin snips to cut the support box from the top corners down to the roof line and fold the resulting flaps toward the inside of the structure. See Figure 23.
- Nail the flaps to the roof AFTER running a bead of non-hardening sealant between the flaps and the roof.
- Clean out ALL materials from inside the support box and complete the vertical vent run and termination.

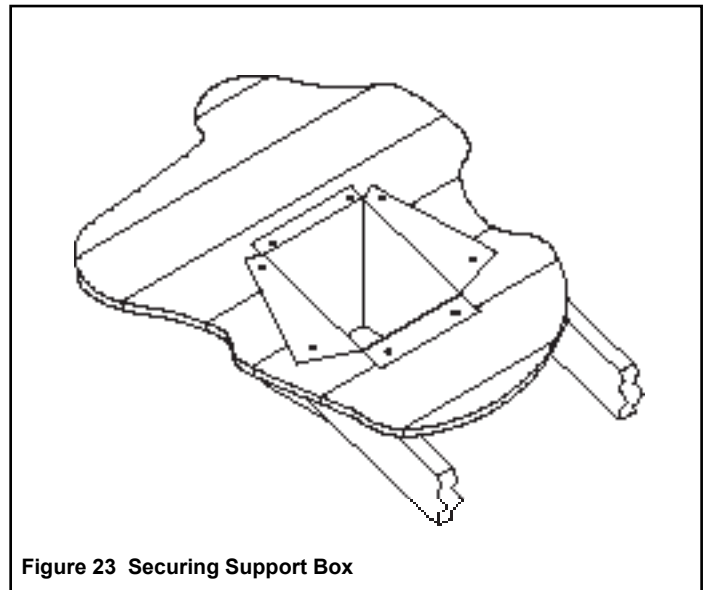
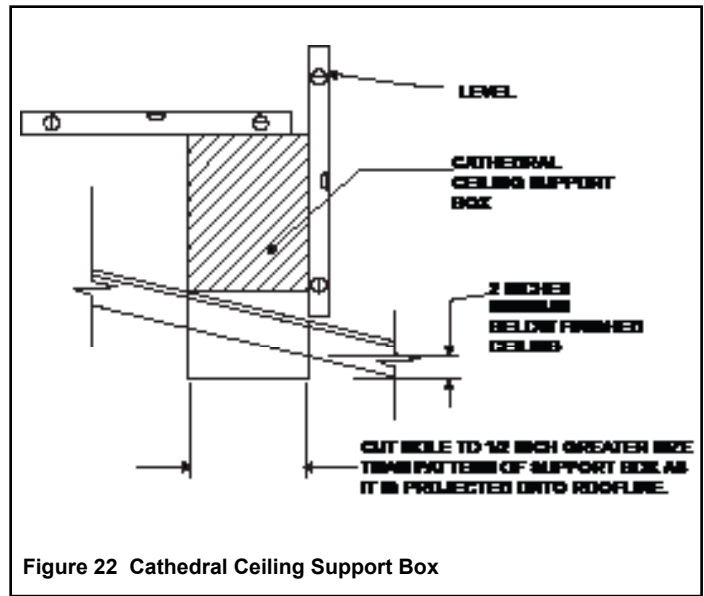

## J. Installing RF4-8

The RF4-8 may be used in place of the roof flashing and storm collar.

Pipe must be supported at roofline using plumbers strapping or an SLP-FS when using the RF4-8 Flashing.

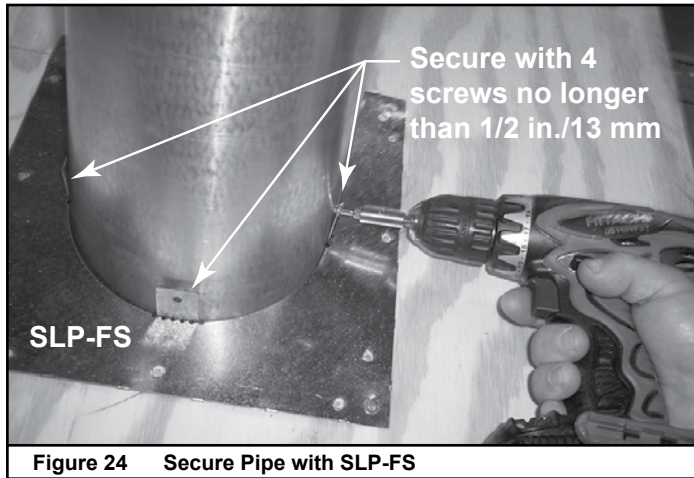

Figure 24 Secure Pipe with SLP-FS

- Trim the rubber boot (using scissors or a utility knife), cutting along the marked measurement lines. See Figure 25. Use the 150 mm line for SLP, 210 mm for DVP.
- Lubricate pipe or flue with water and slide the flashing down. It may be necessary to trim the top shingles around the base of the rubber boot to ensure a good fit.
- Draw around flashing, slide up.
- Apply silicone sealant to roof inside the lines (Figure 26)
- Lubricate pipe or flue with water and slide flashing down. Seat firmly in sealant. Nail roof flashing to the roof.
- Apply silicone sealant on the top outside of the base plate on the sides and on top edge. See Figure 27. Install shingles, Apply sealant at the top edge of the rubber boot. See Figure 28.
- We recommend that you top coat with conventional acrylic house paint to improve the appearance of your galvanized base flashing.

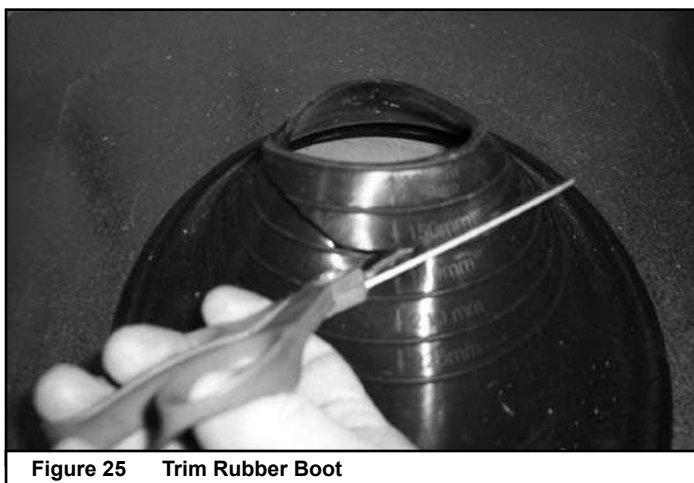

Figure 25 Trim Rubber Boot

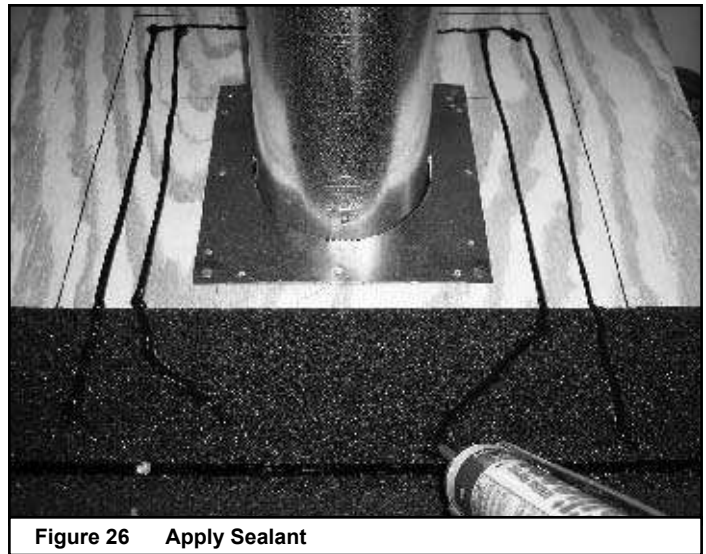

Figure 26 Apply Sealant

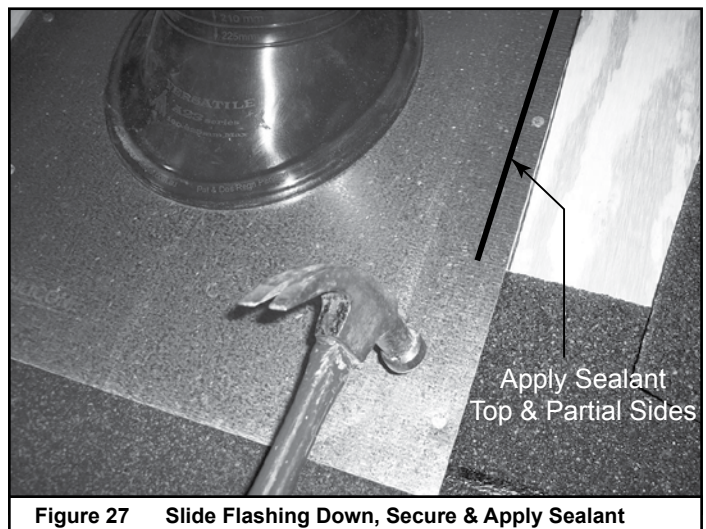

Figure 27 Slide Flashing Down, Secure & Apply Sealant

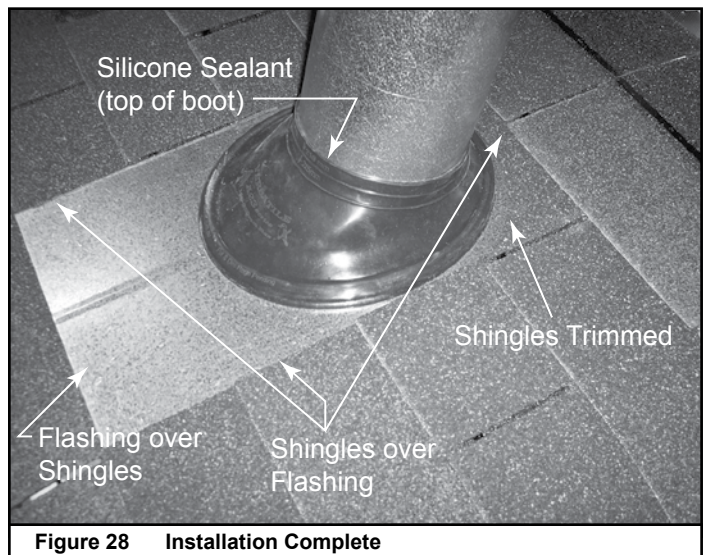
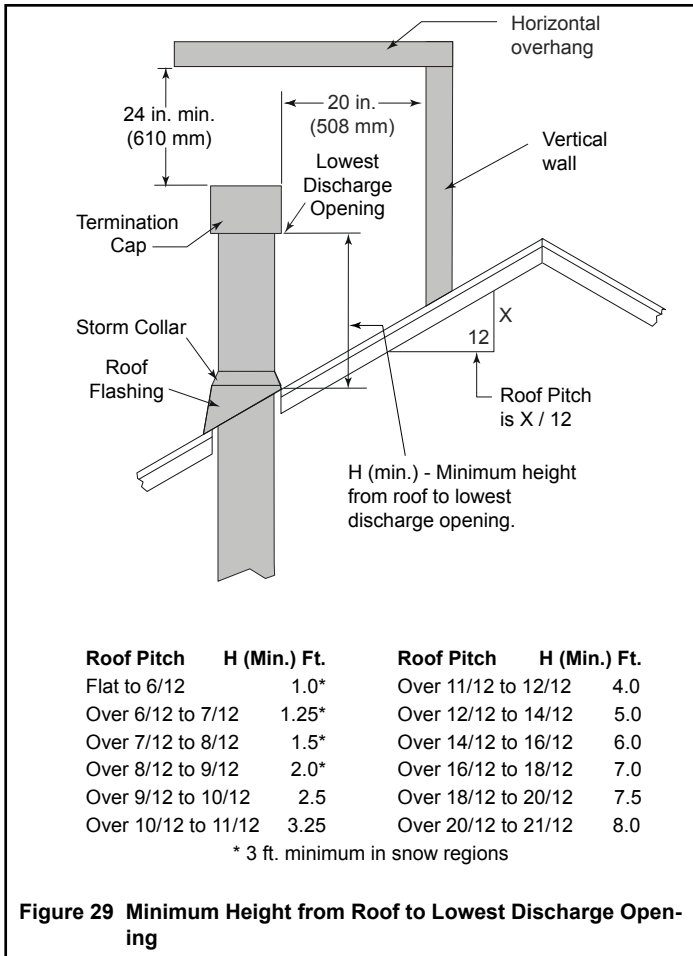

Figure 28 Installation Complete

## K. Install Roof Flashing and Vertical Termination Cap

To install roof flashing see Figures 30 and 31.

For installation of vertical termination cap see minimum vent heights for various pitched roofs (see Figure 29).



Caulk the gap between the roof flashing and the outside diameter of the pipe. Caulk the perimeter of the flashing where it contacts the roof surface.

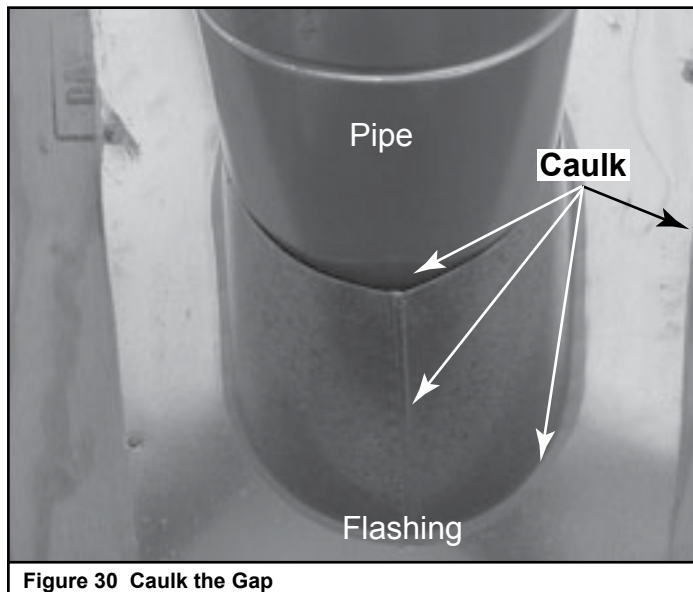

To attach the vertical termination cap, slide the inner collar of the cap into the inner flue of the vent section and place the outer collar of the cap over the outer flue of the vent section.

Secure the cap by driving the three self-tapping screws (supplied) through the pilot holes or dimples in the outer collar of the cap into the outer flue of the vent.



## L. Assemble and Install Storm Collar

**Note:** The storm collar is not utilized when using RF4-8 Flashing. See Section J.

Connect both halves of the storm collar with two screws. Wrap the storm collar around the exposed pipe section and align brackets. Insert a bolt (provided) through the brackets and tighten nut to complete the storm collar assembly. Make sure the collar is tight against the pipe section.

Slide the assembled storm collar down the pipe section until it rests on the roof flashing.

Caulk around the top of the storm collar.